

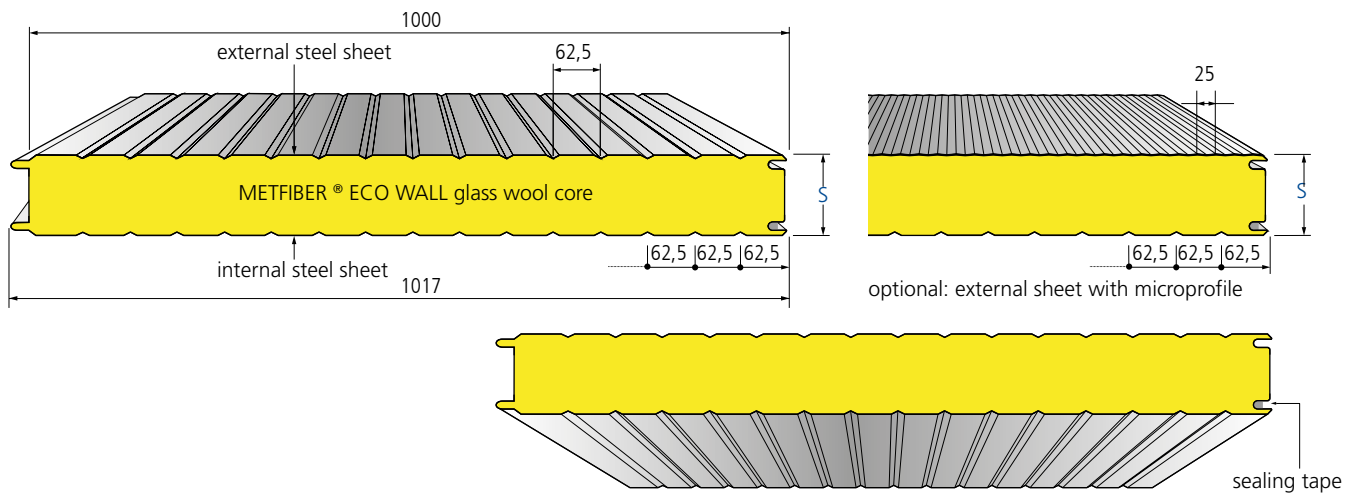

The Metfiber® Eco Wall panel with glass wool core fulfils all the requirements for non-combustible building materials. The glass wool used in this product consists of 80% recycled material, contributing significantly to the saving of natural resources and making the product an ecological building material. The deadweight of the panel is distinctly lower than that of conventional sandwich panels with rock wool insulation core, hence enabling an easier,

faster installation and cost reduction, especially for larger panels. Due to the large number of combinations with other panels from our portfolio with polyurethane or rock wool insulation core, it is possible to reach fire, acoustic and thermal requirements at once without any visual impact. More information is available in the download area www.en.metecno.de.



different internal profiles on request, dimensions in mm

type of element	core thickn. s	external steel sheet t _N	internal steel sheet t _N	weight	thermal resistance R	thermal conductivity [Ψ - joint effect]	
						U w/o Ψ	U with Ψ
	mm	mm	mm	kg / m ²	m ² K / W	W / m ² K	W / m ² K
METFIBER® ECO WALL 	100	0,50	0,50	15,14	2,54	0,384	0,390
	120	0,50	0,50	16,44	3,05	0,321	0,325
	150	0,50	0,50	18,39	3,82	0,257	0,260
	200	0,50	0,50	21,64	5,10	0,194	0,195
	240*	0,50	0,50	24,24	6,12	0,161	0,162
	* no approval / on request						



PRODUCTION AND LABELING

Production according to applicable European Building Product Regulation as per sandwich norm DIN EN 14509 label-marking in accordance with EC certificate of conformity 0769-CPR-VAS-00420

APPLICATION APPROVAL

Current approvals, certificates and general building permits at www.en.metecno.de/service.

REACTION TO FIRE

Building material classified as A2-s1,d0 non-combustible according to DIN EN 13501-1; insulation core made of glass wool

FIRE RESISTANCE*

EI 45 vertical installation (100mm core thickness)
EI 60 horizontal installation (100mm core thickness)

THERMAL CONDUCTIVITY

$\lambda = 0.039 \text{ W / m.K}$ according to DIN 4108 and DIN EN 13162 The insulation values are regularly monitored by external bodies and may be applied without any further reduction.

SOUND INSULATION

$R_w \geq 31 \text{ dB}$

STANDARD LENGTHS

> 2.00 m to 25.00 m, greater lengths on request

STANDARD COATING

External and internal steel sheet: 25 μm polyester
For standard colours and different coating systems please refer to our colour chart

CORROSION PROTECTION

According to DIN EN 10169:

External sheet: Class RC3

Internal sheet: Class RC3

According to DIN EN ISO 12944-2:

External and internal sheets: corrosivity category C3

corresponding to average duration of protection for urban and industrial environments with moderate exposure to sulphur dioxide

Other coating systems are available for more sophisticated demands such as for buildings near the sea, farm buildings with high ammonia exposure or moist rooms

STANDARD STEEL SHEETS

Hot-dip galvanized steel, grade S 320 GD + Z275 according to DIN EN 10346

TABLE OF SPANS

Please visit our website www.en.metecno.de

PACKAGING

External sheets provided with removable protective film, panel packages wrapped with banded plastic foil to protect from soiling

INTERLOCKING JOINT COMPATIBILITY WITH THERMOWALL
KOMBI® & HIPERTEC® WALL

* no approval / on request

